

**Our Products Make Your Product Better®**

To learn more about EMAC's products and services and how they can help your project

[http://ftp.emacinc.com/Tech\\_Info/About\\_EMAC\\_Products\\_and\\_Services.pdf](http://ftp.emacinc.com/Tech_Info/About_EMAC_Products_and_Services.pdf)



Authorized Distributor, Integrator, and Value-Added Reseller

Manual downloaded from <ftp.emacinc.com>

For purchase information please contact [info@emacinc.com](mailto:info@emacinc.com)

For technical support please submit a ticket at [www.emacinc.com/support](http://www.emacinc.com/support)

# User's Manual

Version 1.1

## EMC-i613

PC/104 Embedded Intel Celeron ULV  
400MHz CPU Model with one SODIMM up  
to 512 MB SDRAM, CRT/Flat Panel  
SVGA, one Realtek 8100BL Fast Ethernet

---

**Copyright® 2003**

**All Rights Reserved.**

The information in this document is subject to change without prior notice in order to improve the reliability, design and function. It does not represent a commitment on the part of the manufacturer.

Under no circumstances will the manufacturer be liable for any direct, indirect, special, incidental, or consequential damages arising from the use or inability to use the product or documentation, even if advised of the possibility of such damages.

This document contains proprietary information protected by copyright. All rights are reserved. No part of this manual may be reproduced by any mechanical, electronic, or other means in any form without prior written permission of the manufacturer.

---

# Warning

Single Board Computers and their components contain very delicate Integrated Circuits (IC). To protect the Single Board Computer and its components against damage from static electricity, you should always follow the following precautions when handling it :

1. Disconnect your Single Board Computer from the power source when you want to work on the inside
2. Hold the board by the edges and try not to touch the IC chips, leads or circuitry
3. Use a grounded wrist strap when handling computer components.
4. Place components on a grounded antistatic pad or on the bag that came with the Single Board Computer, whenever components are separated from the system
5. The "CPU" needs the Heat Sink on it.
6. The "Northbridge" needs the Heat Sink or fan on it.

## Technical Support

If you have any technical difficulties, please consult the user's manual first at:

<ftp://ftp.emacinc.com>

Please do not hesitate to call or e-mail our customer service when you still can not find out the answer.

<http://www.emacinc.com>

E-mail: [support@emacinc.com](mailto:support@emacinc.com)

---

## Table of Contents

<b>Technical Support</b> .....	<b>3</b>
<b>Specifications</b> .....	<b>6</b>
General Specifications .....	6
High Speed Multi I/O .....	6
Network Interface Controller .....	6
Environmental and Power .....	7
<b>Board Layout Top View (Front)</b> .....	<b>8</b>
<b>Board Layout View (Back)</b> .....	<b>9</b>
<b>Board Dimension</b> .....	<b>10</b>
<b>Jumper/Connector Quick Reference</b> .....	<b>11</b>
<b>Jumper/Connector Quick Reference</b> .....	<b>12</b>
<b>CMOS Jumper Settings</b> .....	<b>13</b>
<b>Serial Port Selection (RS232C/422/485)</b> .....	<b>14</b>
RS-422/485 Mode on COM2 .....	14
<b>CPU Fan Connector</b> .....	<b>15</b>
<b>LAN LED Connector</b> .....	<b>16</b>
<b>VGA Connector</b> .....	<b>17</b>
<b>Flat Panel VGA</b> .....	<b>18</b>
<b>COM1 &amp; COM2 Connectors</b> .....	<b>19</b>
COM1 RS-232 .....	19
COM2 with RS-232/422/485 Mode .....	19
<b>Enhanced IDE Connector</b> .....	<b>20</b>
<b>FDD Connector</b> .....	<b>21</b>
<b>USB Connector</b> .....	<b>22</b>
<b>Infrared (IR) Connector</b> .....	<b>23</b>
<b>Keyboard &amp; PS/2 Mouse</b> .....	<b>23</b>

---

<b>Parallel Port Connector .....</b>	<b>24</b>
<b>Small 4P Power Connector .....</b>	<b>25</b>
<b>100 Base-Tx Ethernet Connector .....</b>	<b>26</b>
<b>Switches and Indicators .....</b>	<b>27</b>
<b>System Resources .....</b>	<b>28</b>
<b>Watchdog Timer .....</b>	<b>31</b>
Timeout Values .....	31
Timeout Table .....	31

---

## Specifications

### General Specifications

- **CPU** : Intel Ultra Low Voltage Embedded Celeron 400MHz to Pentium III 933MHz processor with FSB 100/133 MHz uBGA package.
- **Chipset** : VIA VT8606 100/133 MHz North Bridge, VIA VT82C686B
- **Display Controller** : VIA 8606 Integrated Savage4 2D/3D Video Accelerator, 32MB Shared Memory, 4 x AGP
- **Display type** : CRT (VGA, SVGA, XGA, SVGA) and LCD
  - >Chipset: VIA8606 Integrated Savage4 2D/3D Video Accelerator, 4x AGP and 128-bit engine
  - >Display Memory: 8/16/32MB Shared Memory
  - >Display Type: Flat Panel and CRT displays
  - >Resolution: Up to 1280 x 1024 @ 32bpp
  - >LCD Interface: Flat Panel 36-bit TFT/DSTN interface
- **Extensive LCD Support** : 8 x 2 pin header, supports LCD display TTL
- **BIOS** : AWARD® Flash BIOS
- **Green Function** : power saving supported in BIOS. DOZE / STANDBY
- **L2 Cache** : Integrated on CPU (256 KB ~ 512 KB)
- **DRAM Memory** : One 144-pin SODIMM socket supports up to 512MB
- **IDE Interface** : 44-pin connector x 1 (IDE supports DMA33)
- **Real Time Clock** : RTC with Lithium Battery

### High Speed Multi I/O

- **Chipset** : VIA VT8606
- **Serial Ports** : Two high speed COM ports, one is high speed RS-232C and the other is RS232C/422/485 port (jumper selectable). Both with 16C550 compatible UART and 16 byte FIFO.
- **USB** : 2 onboard USB ver 1.1 ports
- **Extension Bus** : PC/104
- **Flash EPROM** : 2MB EPROM and combined BIOS support
- **Watchdog Timer** : 1 - 255 sec, system reset or NMI

---

## Network Interface Controller

- **Chipset** : Realtek 8100BL chip
- **Interface** : IEEE802.3U compatible 10/100 Base-T interface includes software driver and boot ROM function

## SSD Interfaces

- **Compact Flash Card (CFC)**
  - **Compact Flash Socket** : supports Type I/II CFC
  - **Capacity** : up to 1 GB CFC

## Environmental and Power

- **Power Requirements** : +5 V @ 2.1 A (typical);(ULV Celeron 400MHz and 512MB SDRAM)
- **System Monitoring and Alarm** : CPU and System temperature, system voltage .
- **Board Dimensions** : 90mm x 96mm (3.5" x 3.8")
- **Board Weight** : 0.11kg
- **Operating Temperature** : 0 to 60°C (32 to 140°F)



## Board Layout Top View (Front)

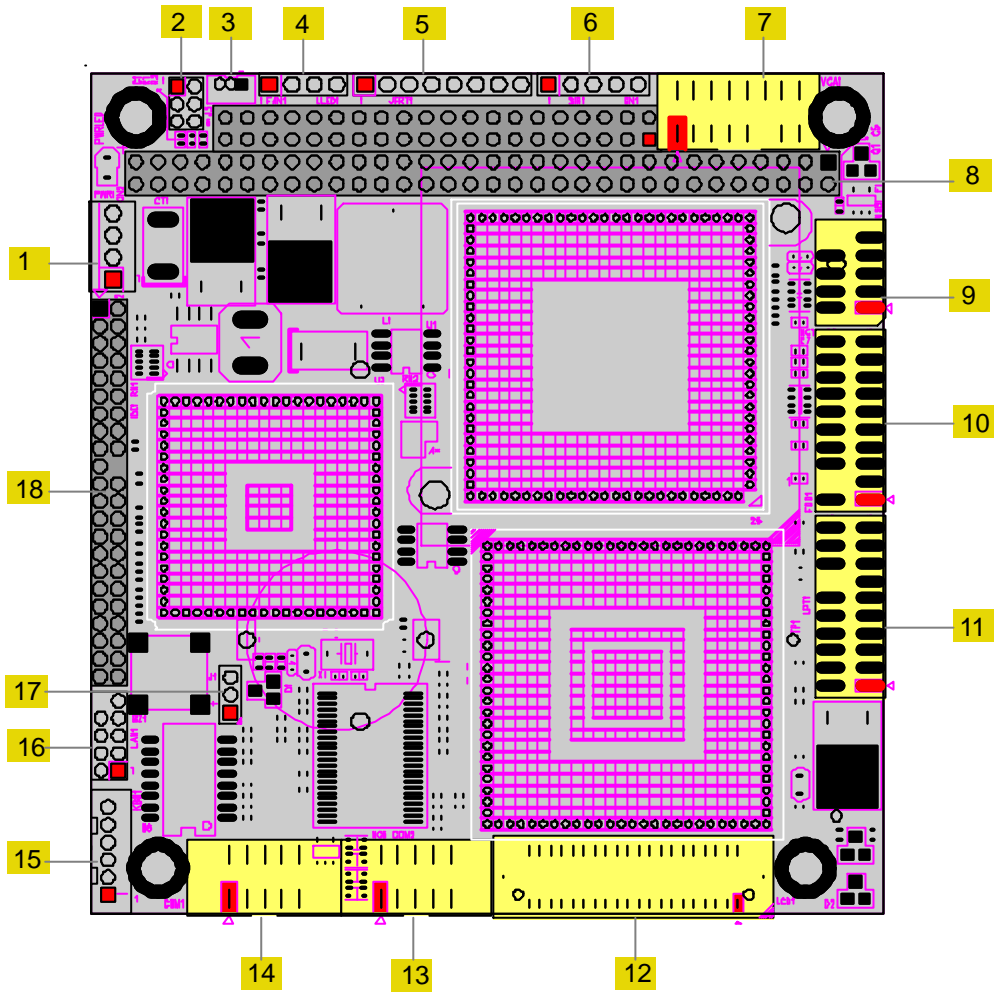

- |          |           |          |          |
|----------|-----------|----------|----------|
| 1. PWR1  | 6. SIR1   | 11. LPT1 | 16. LAN1 |
| 2. J5    | 7. VGA1   | 12. LCD1 | 17. J1   |
| 3. FAN1  | 8. PC 104 | 13. COM2 | 18. IDE1 |
| 4. LLED1 | 9. USB1   | 14. COM1 |          |
| 5. JFRT1 | 10. FDD1  | 15. KBM1 |          |

## Board Layout View (Back)

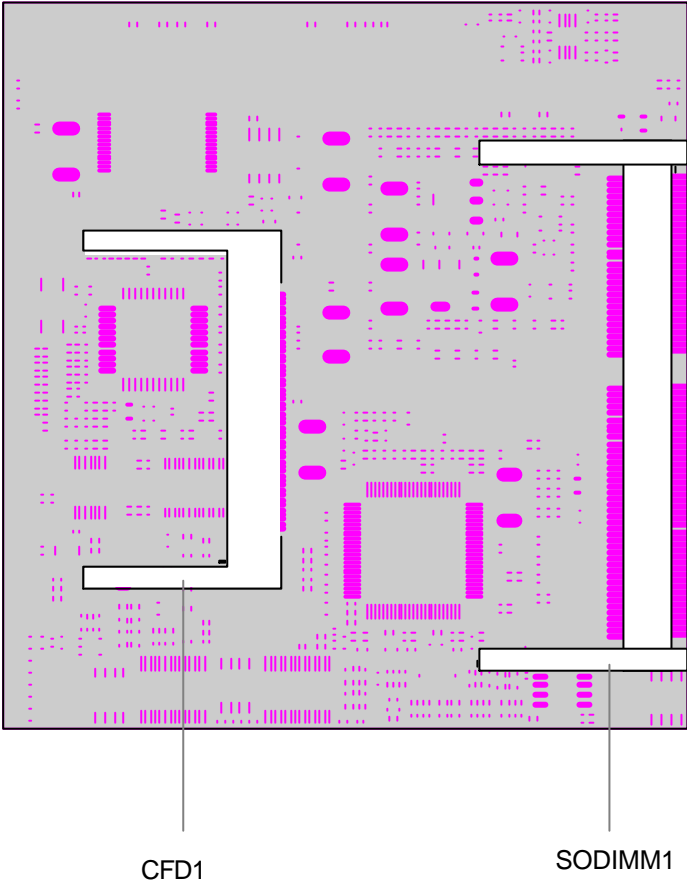

---

**Board Dimension**

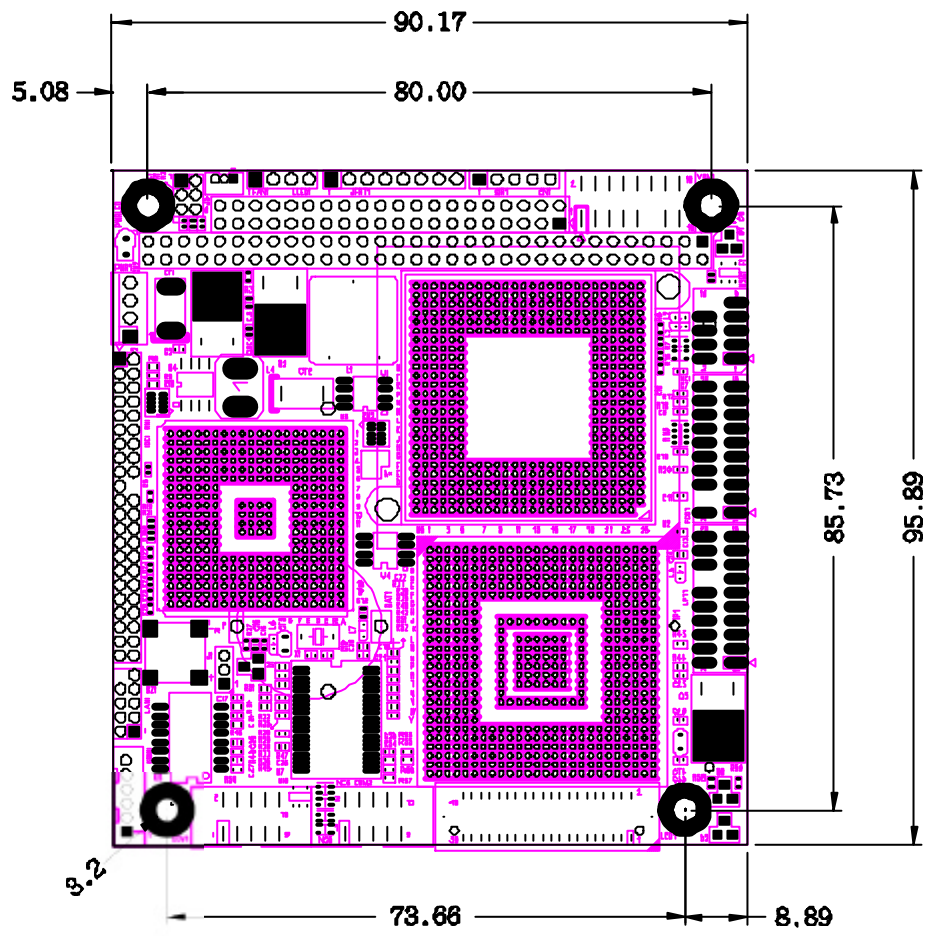

---

## Jumper/Connector Quick Reference

### Jumpers

Label	Function
J1	Clear CMOS
J5	COM2 RS-232/422/485 Selection

---

## Jumper/Connector Quick Reference

Connector	
Label	Function
VGA1	VGA Display Connector
LCD1	18&24 Bit LCD Connector (DF-13 40 pin)
IDE1	IDE Hard Drive Connector
CFD1	Compact Flash Connector
USB1	USB 0-1 Connector
SIR1	IrDA Connector
KBM1	Keyboard and PS/2 Mouse Connector
FDD1	Floppy Drive Connector
LPT1	Parallel Port Connector
COM1	COM1 RS-232 Serial Port Connector
COM2	COM2 RS-232/422/485 Serial Port Connector
PWR1	Small 4P Power Connector
LAN1	100 Base-Tx Ethernet Connector
LLED1	LAN LED
JFRT1 (1-2)	Front Panel (Reset Switch)
JFRT1 (3-4)	Front Panel (External SMI)
JFRT1 (5-6)	Front Panel (HDD LED)
JFRT1 (7-8)	Front Panel (External Speaker)

---

## CMOS Jumper Settings

### CMOS Operation (J1)

Type : onboard 3-pin header

If the EMC-i613 refuses to boot due to inappropriate CMOS settings here is how to proceed to clear (reset) the CMOS to its default values.

CMOS Setup (J1)	J1	Status
Normal Operation	1-2	ON
Clear CMOS	2-3	ON
default setting	1-2 ON	

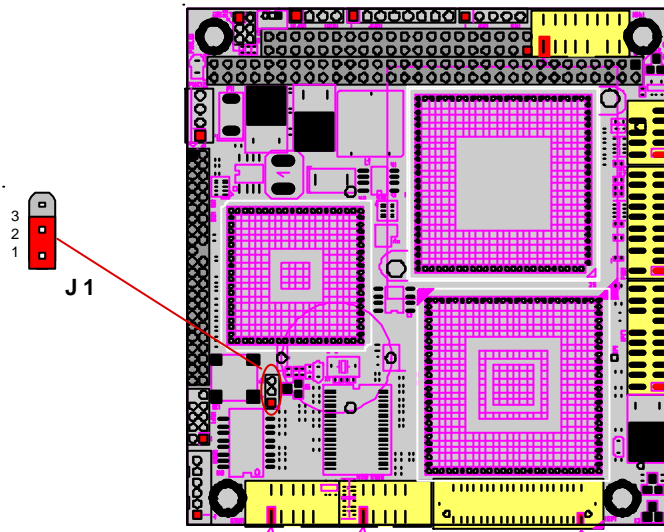

---

## Serial Port Selection (RS232C/422/485)

### RS-232C/422/485 Mode select (J5)

Type : onboard 6-pin(2\*3) header

J5 Selection	1-2	3-4	5-6
RS-232C	ON	OFF	OFF
RS-422	OFF	ON	OFF
RS-485	OFF	OFF	ON

default setting RS-232C

### RS-422/485 Mode on COM2

The onboard COM2 port can be configured to operate in RS-422 or RS-485 modes. RS-422 modes differ in the way RX/TX is being handled. Jumper J5 switches between RS-232C or RS-422/485 mode. All of the RS-232C/422/485 modes are available on COM2.

#### COM2

Pin Defined:	RS-232C	RS-422	RS-485
Pin1 :	DCD	Tx+	RTx+
Pin2 :	RXD	Tx-	RTx-
Pin8 :	CTS	Rx+	x
Pin9 :	RI	Rx-	x

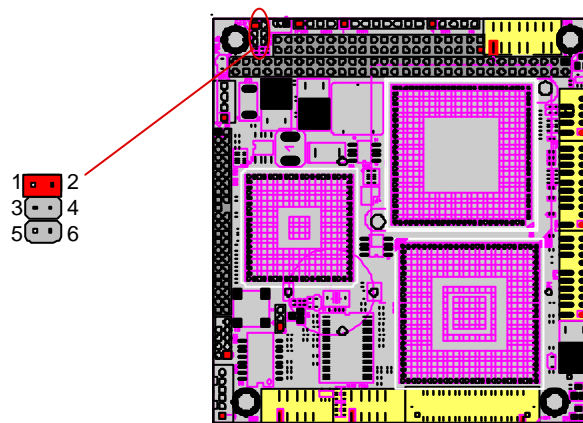

---

## CPU Fan Connector

Connector : **FAN1**

Type : onboard 3-pin wafer connector

Pin	Description
1	FAN_CTL
2	+5V
3	GND

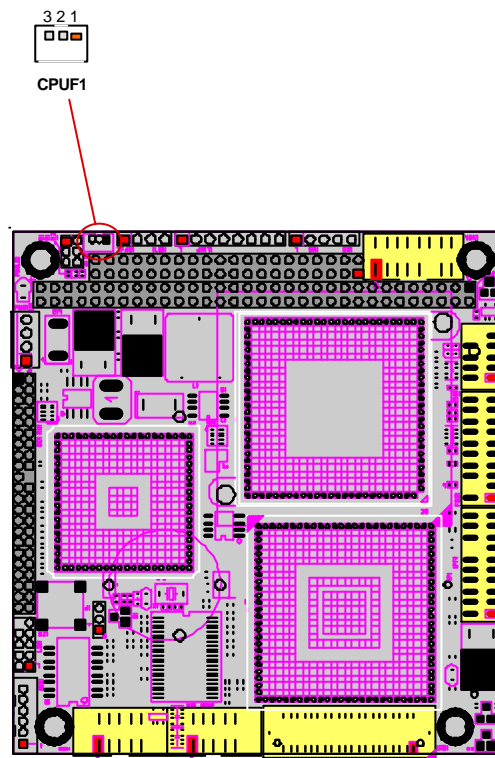



---

## LAN LED Connector

Connector : **LLED1**

LAN LED can be indicated when the Network is on or off.

Type : Onboard 4-pin header

Pin	Description
1	ACTLED-
2	+3.3V
3	LINKLED-
4	+3.3V

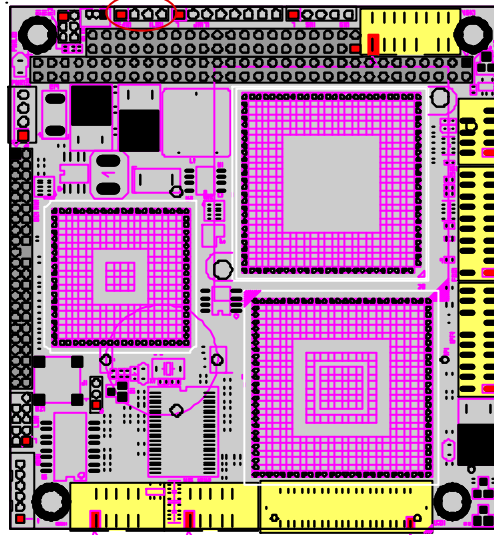

---

## VGA Connector

Connector : VGA1 Connector

Type: Onboard 16-pin mini boxheader

Pin	Description	Pin	Description	Pin	Description
1	RED	6	GND	11	NC
2	GREEN	7	GND	12	VDDAT
3	BLUE	8	GND	13	HSYNC
4	NC	9	Vcc	14	VSYNC
5	GND	10	GND	15	VDCLK
16	NC				

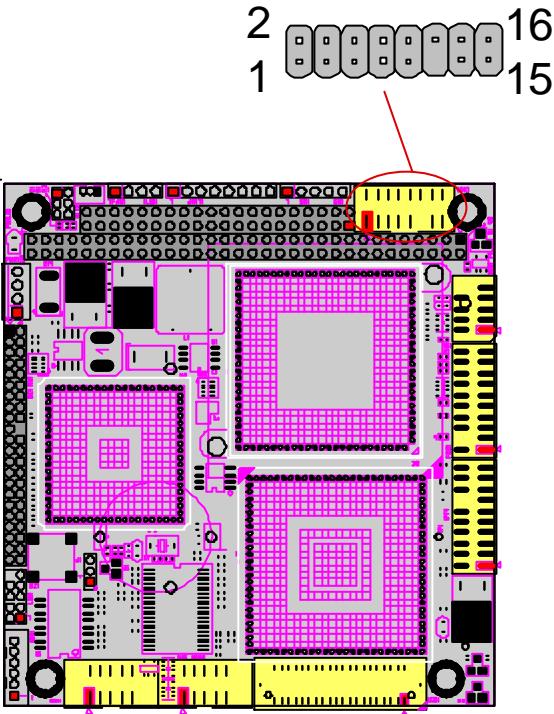

---

## Flat Panel VGA

### LCD1

Type : Onboard 40-pin Box Header (Hirose DF-40DS-1.25C)

Pin	Description	Pin	Description
1	VCC5V	2	VCC5V
3	GND	4	GND
5	VCC3V	6	VCC3V
7	NC	8	GND
9	FPD0	10	FPD1
11	FPD2	12	FPD3
13	FPD4	14	FPD5
15	FPD6	16	FPD7
17	FPD8	18	FPD9
19	FPD10	20	FPD11
21	FPD12	22	FPD13
23	FPD14	24	FPD15
25	FPD16	26	FPD17
27	FPD18	28	FPD19
29	FPD20	30	FPD21
31	FPD22	32	FPD23
33	GND	34	GND
35	SHFCLK	36	HSYNC
37	M(DE)	38	VSYNC
39	ENBLK	40	ENAVEE

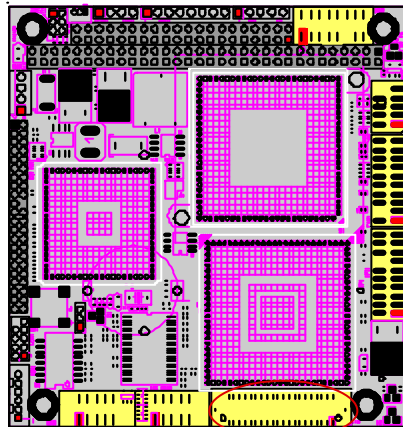

1

---

## COM1 & COM2 Connectors

### COM1 RS-232

Connector : COM1

Type : Onboard 10-pin header

Pin	Description	Pin	Description
1	DCD1	2	RXD1
3	TXD1	4	DTR1
5	GND	6	DSR1
7	RTS1	8	CTS1
9	RI	10	NC

### COM2 with RS-232/422/485 Mode

Connector : COM2

Type : onboard 10-pin header

Pin	Description	Pin	Description
1	DCD2(422TXD+/485DATA+)	2	RXD2(422TXD-/485DATA-)
3	TXD2	4	DTR2
5	GND	6	DSR2
7	RTS2	8	CTS(422RXD+)
9	RI(422RXD-)	10	NC

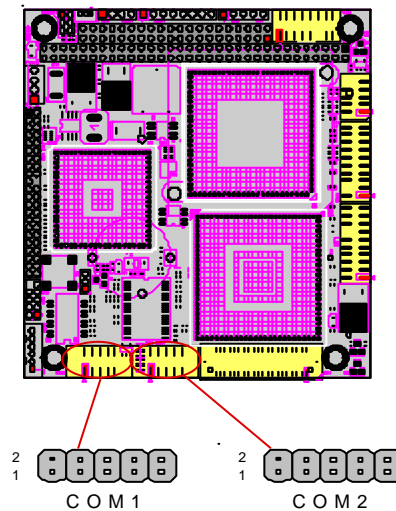

## Enhanced IDE Connector

Connector : **IDE1**

Type : Onboard 44-pin box headers

Pin	Description	Pin	Description
1	#RESET	2	GND
3	D7	4	D8
5	D6	6	D9
7	D5	8	D10
9	D4	10	D11
11	D3	12	D12
13	D2	14	D13
15	D1	16	D14
17	D0	18	D15
19	GND	20	NC/(Vcc)
21	REQ	22	GND
23	IO RWITE	24	GND
25	IO READ	26	GND
27	IO READY	28	GND
29	DACK	30	GND
31	IRQ14	32	NC
33	ADDR1	34	ATA66 DETECT
35	ADDR0	36	ADDR2
37	CS#1	38	CS#3
39	IDEACTP	40	GND
41	VCC(+5V)	42	VCC(+5V)
43	GND	44	NC

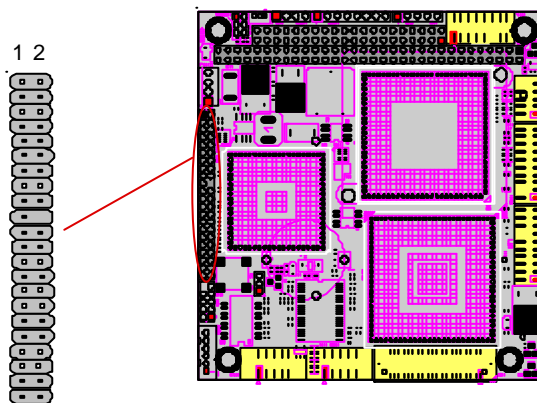

---

## FDD Connector

Connector : FDD1

Type : Onboard 20-pin header

Pin	Description	Pin	Description
1	GND	2	Drive density select 0
3	GND	4	NC (Key)
5	GND	6	Drive density select 1
7	#Write data	8	#Index
9	#Write gate	10	#Motor enable A
11	#Track 0	12	#Driver select B
13	#Write protect	14	#Driver select A
15	#Read data	16	#Motor enable B
17	#Head select	18	#Direction
19	#Disk change	20	#Step

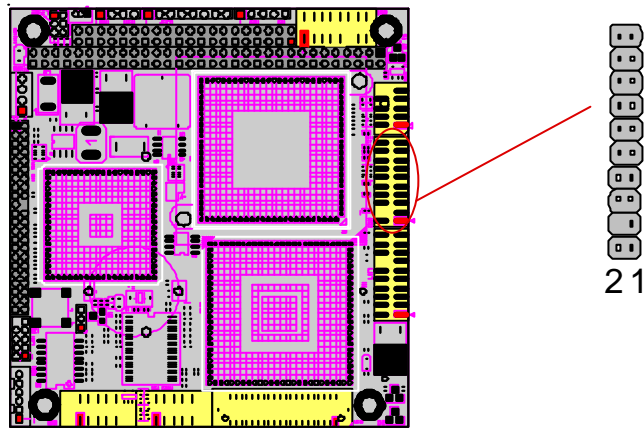

---

## USB Connector

Connector : USB1 connector

Type: onboard Two 8-pin box headers

Pin	Description	Pin	Description
1	+5V	2	+5V
3	USBD0-	4	USBD1-
5	USBD0+	6	USBD1+
7	GND	8	GND
9	GND	10	NC

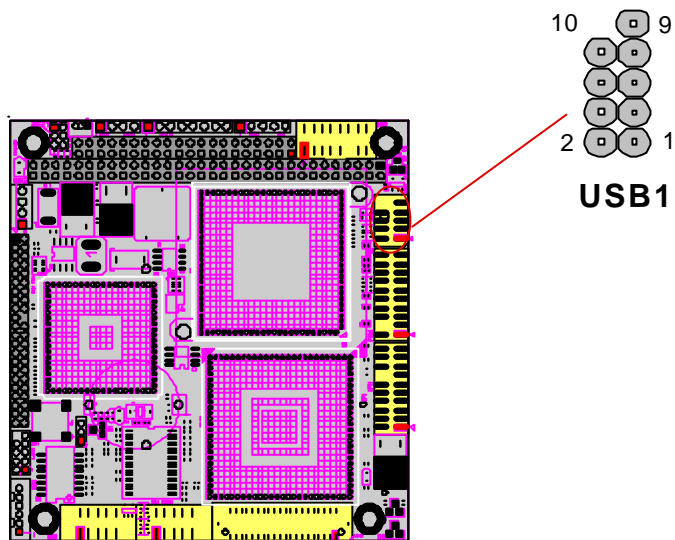

---

## Infrared (IR) Connector

Connector : **SIR**

Type : SIR1: onboard 5-pin header

Pin	Description	Pin	Description
1	+5V	2	NC
3	IRRX	4	GND
5	IRTX		

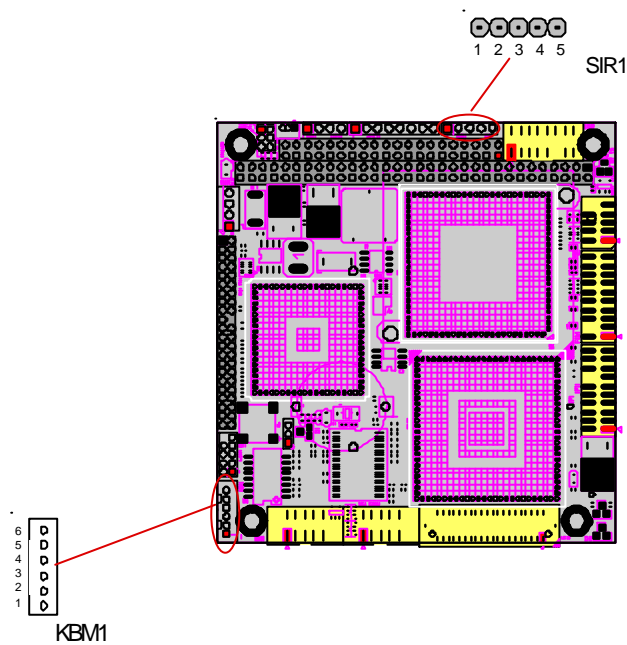

## Keyboard & PS/2 Mouse

Connector : **KBM1**

Type : KBM2: onboard waver 6-pin (JST PHR-6)

Pin	Description	Pin	Description
1	KB_DATA	2	GND
3	MS_DATA	4	KB_CLK
5	+5V	6	MS_CLK



---

## Parallel Port Connector

Connector : LPT1

Type : Onboard 20-pin header

Pin	Description	Pin	Description
1	#STROBE	2	#Auto feed
3	PTD 0	4	#Error
5	PTD 1	6	#Initialize
7	PTD 2	8	#Select Input
9	PTD 3	10	GND
11	PTD 4	12	GND
13	PTD 5	14	NC (KEY)
15	PTD 6	16	Busy
17	PTD 7	18	Paper Empty
19	#Acknowledge	20	Select

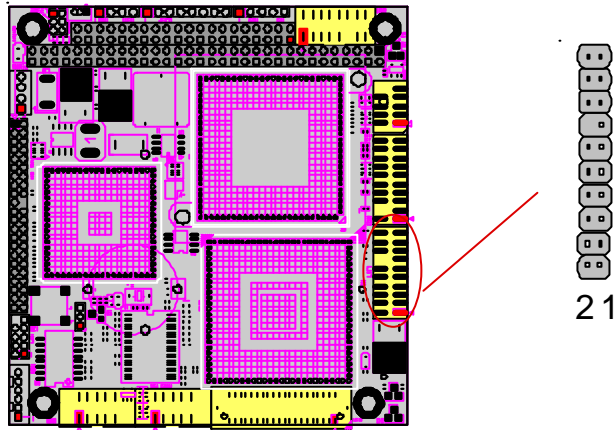

---

## Small 4P Power Connector

Connector : **PWR1**  
Type : 4 pin

Pin	Description	Pin	Description
1	+5V	2	GND
3	GND	4	+12V

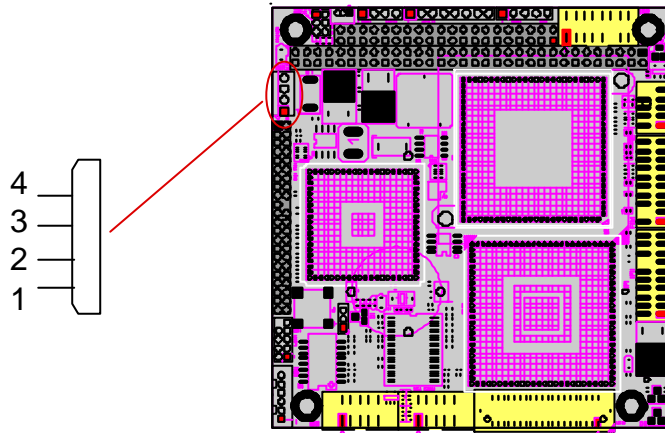

---

## 100 Base-Tx Ethernet Connector

Connector : LAN1

Type : onboard 10-pin header

Pin	Description	Pin	Description
1	TX+	2	TX-
3	RX+	4	NC
5	NC	6	RX-
7	NC	8	NC
9	GND	10	NC

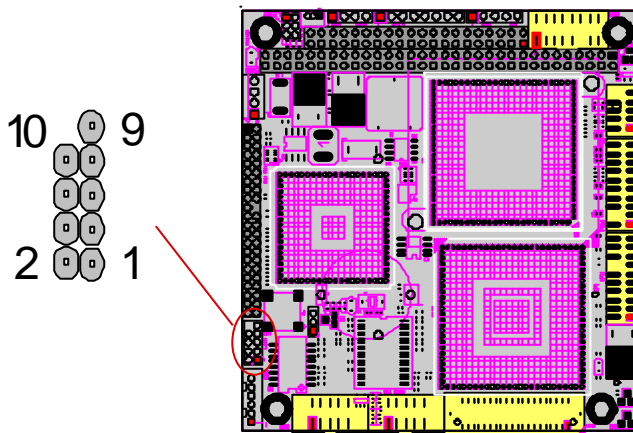

---

## Switches and Indicators

Connector : **JFRT1**

Type : onboard 8-pin header

Pin	Jumper	Description
1-2	RES	Reset
3-4	ESMI	External SMI
5-6	HDD	Pin-5 is "HDD+",Pin6 is "HDD-"
7-8	SPEAKER	Pin-7 is "SPEAKER+",Pin-8 is "SPEAKER-"

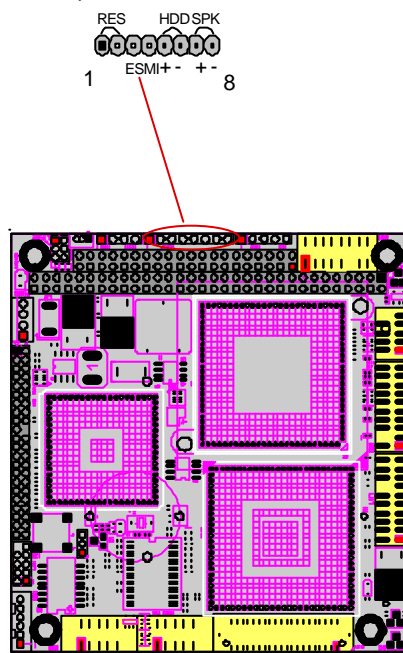

---

## System Resources

### *Interrupt Assignment*

<b>IRQ Address</b>	<b>Description</b>
0	System Timer
1	Standard 101/102-Key or Microsoft Natural Keyboard
2	Programmable Interrupt Controller
3	Communications Port (COM2)
4	Communications Port (COM1)
5	IRQ Holder for PCI Steering
5	VIA Tech 3038 PCI to USB Universal Host Controller
6	Standard Floppy Disk Controller
7	ECP Printer Port (LPT1)
8	System CMOS/real time clock
10	S3 Graphics Twister
10	IRQ Holder for PCI Steering
11	Realtek RTL 8139(A/B/C/8130) PCI Fast Ethernet NIC
11	IRQ Holder for PCI Steering
12	PS/2 Mouse
13	Numeric data processor
14	Primary IDE Controller
14	VIA Bus Master PCI IDE Controller
15	Secondary IDE Controller
15	VIA Bus Master PCI IDE Controller

### *Direct Memory Access*

<b>DMA</b>	<b>Description</b>
2	Standard Floppy Disk Controller
3	ECP Printer Port (LPT1)
4	Direct memory access controller

---

**I/O Address Description**

0000 - 000F	Direct memory access controller
0020 - 0021	Programmable interrupt controller
0040 - 0043	System timer
0060 - 0060	Standard 101/102-Key or Microsoft Natural Keyboard
0061 - 0061	System speaker
0064 - 0064	Standard 101/102-Key or Microsoft Natural Keyboard
0070 - 0071	System CMOS/real time clock
0081 - 0083	Direct memory access controller
0087 - 0087	Direct memory access controller
0089 - 008B	Direct memory access controller
008F - 0091	Direct memory access controller
00A0 - 00A1	Programmable interrupt controller
00C0 - 00DF	Direct memory access controller
00F0 - 00FF	Numeric data processor
0170 - 0177	VIA Bus Master PCI IDE Controller
0170 - 0177	Secondary IDE controller (dual fifo)
01F0 - 01F7	VIA Bus Master PCI IDE Controller
02F8 - 02FF	Primary IDE controller (dual fifo)
02F8 - 02FF	Communications Port (COM2)
0376 - 0376	VIA Bus Master PCI IDE Controller
0376 - 0376	Secondary IDE controller (dual fifo)
0378 - 037F	ECP Printer Port (LPT1)
03B0 - 03BB	S3 Graphics Twister
03C0 - 03DF	S3 Graphics Twister
03F0 - 03F5	Standard Floppy Disk Controller
03F6 - 03F6	VIA Bus Master PCI IDE Controller
03F6 - 03F6	Primary IDE controller (dual fifo)
03F7 - 03F7	Standard Floppy Disk Controller
03F8 - 03FF	Communications Port (COM1)
04D0 - 04D1	PCI bus
0778 - 077F	ECP Printer Port (LPT1)
0CF8 - 0CFF	PCI bus
4000 - 407F	PCI bus
4080 - 40FF	PCI bus
5000 - 501F	PCI bus
6000 - 607F	PCI bus
E000 - E007	Primary IDE controller (dual fifo)
E000 - E00F	VIA Bus Master PCI IDE Controller

---

E008 - E00F	Secondary IDE controller (dual fifo)
E400 - E41F	VIA Tech 3038 PCI to USB Universal Host Controller
E800 - E81F	VIA Tech 3038 PCI to USB Universal Host Controller
EC00 - ECFE	Realtek RTL8139/810x Family Fast Ethernet NIC

---

---

## Watchdog Timer

### Watchdog Output

The onboard watchdog timer can be disabled by BIOS setting or enable for either reboot by system RESET.

Even if enabled by BIOS setting upon boot the watchdog timer is always inactive. To initialize or refresh the watchdog timer writing of port 444H is sufficient. To disable the watchdog time read port 44H.

Status	Action
Enable/refresh the Watchdog Timer	I/O Write 444H
Disable the Watchdog Timer.	I/O Read 044H

After the watchdog timer has been initialized by reading port 444H, it has to be strobed at preconfigured intervals to keep it from issuing a RESET or NMI.

The watchdog timer timeout intervals are set by software programming.

### Timeout Values

Timeout values are programmed. The watchdog timer supports 255 steps. use the table on the next page to find the hexadecimal value that needs to be passed on to get the correct timer interval. Look subsequently at the program example how to pass the value to the watchdog timer.

### Timeout Table

Level	Value	Seconds	Level	Value	Seconds	Level	Value	Seconds
1	1	1	2	2	2	3	3	3
4	4	4	5	5	5	6	6	6
7	7	7	8	8	8	9	9	9
10	A	10	11	B	11	12	C	12
13	D	13	14	E	14	15	F	15
16	10	16	17	11	17	18	12	18
19	13	19	20	14	20	21	15	21



---

22	16	22	23	17	23	24	18	24
25	19	25	26	1A	26	27	1B	27
28	1C	28	29	1D	29	30	1E	30
31	1F	31	32	20	32	33	21	33
34	22	34	35	23	35	36	24	36
37	25	37	38	26	38	39	27	39
40	28	40	41	29	41	42	2A	42
43	2B	43	44	2C	44	45	2D	45
46	2E	46	47	2F	47	48	30	48
49	31	49	50	32	50	51	33	51
52	34	52	53	35	53	54	36	54
55	37	55	56	38	56	57	39	57
58	3A	58	59	3B	59	60	3C	60
61	3D	61	62	3E	62	63	3F	63
64	40	64	65	41	65	66	42	66
67	43	67	68	44	68	69	45	69
70	46	70	71	47	71	72	48	72
73	49	73	74	4A	74	75	4B	75
76	4C	76	77	4D	77	78	4E	78
79	4F	79	80	50	80	81	51	81
82	52	82	83	53	83	84	54	84
85	55	85	86	56	86	87	57	87
88	58	88	89	59	89	90	5A	90
91	5B	91	92	5C	92	93	5D	93
94	5E	94	95	5F	95	96	60	96
97	61	97	98	62	98	99	63	99
100	64	100	101	65	101	102	66	102
103	67	103	104	68	104	105	69	105
106	6A	106	107	6B	107	108	6C	108
109	6D	109	110	6E	110	111	6F	111
112	70	112	113	71	113	114	72	114
115	73	115	116	74	116	117	75	117
118	76	118	119	77	119	120	78	120
121	79	121	122	7A	122	123	7B	123
124	7C	124	125	7D	125	126	7E	126
127	7F	127						

---

### Programming Example

The following program is an examples of how to enable, disable and refresh the Watchdog timer:

```
WDT_EN_RF      equ      444H

WDT_DIS equ     044h

WT_Enable      push AX          ; Save AX,DX
                push DX
                mov DX,WDT_EN_RF ; Enable Timer
                mov AX,INTERVAL ; Set Timeout Value
                out DX,AX
                pop DX           ; Restore DX,AX
                pop AX
                ret

WT_Refresh     push AX          ; Save AX,DX
                push DX
                mov DX,WDT_EN_RF ; Refresh Timer
                mov AX,INTERVAL ; Set Timeout Value
                out DX,AX
                pop DX           ; Restore DX,AX
                pop AX
                ret

WT_Disable     push AX          ; Save AX,DX
                push DX
                mov DX,WDT_DIS   ; Disable Timer
                in  AX,DX
                pop DX           ; Restore DX,AX
                pop AX
                ret

WT_Disable     push AX          ; save AX,DX
                push DX
                mov DX,WDT_DIS   ; Disable Timer
                in  AX,DX
                pop DX           ; restore DX,AX
                pop AX
                ret
```